







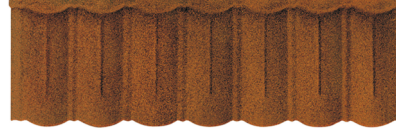

Test Approval

Material	Designation	
Base Steel	ASTM A792 (AZM150)	
Test Item	Test Method	Certified By
Accelerated Weathering 耐人工老化	500H KSF4751 GB/T 16529-1996 1000H ASTM G26	Korea Institute of Construction Materials 中国建筑材料测试中心 Korea Institute of Construction Materials
Humidity Resistance	500H KSF4751	Korea Institute of Construction Materials
Salt Spray Test 耐盐水腐蚀性	500H KSD9502 GB/T 1771-1991 1000H ASTM B117	Korea Chemical Inspection and Testing Institute 中国建筑材料测试中心 Korea Institute of Construction Materials
Pencil Hardness	KSD6711	Korea Chemical Inspection and Testing Institute
Cross Cut 密着性	100/100 KSD6711 GB/T 1720-1979	Korea Chemical Inspection and Testing Institute 中国建筑材料测试中心
Impact Resistance	KSM5307	Korea Chemical Inspection and Testing Institute
Acid Resistance 耐酸性	KSF4751 GB/T 1748-1999	Korea Chemical Inspection and Testing Institute 中国建筑材料测试中心
Alkali Resistance 耐碱性	KSF4751 GB/T 1748-1999	Korea Chemical Inspection and Testing Institute 中国建筑材料测试中心
Heat Resistance	KSF4751	Korea Chemical Inspection and Testing Institute
Fire Resistance	KSF2271 UL 790 (Class 4)	Korea Institute of Construction Materials Underwriters Laboratories, U.S.A.
Fire Test	Certificate No.: NM-0049	Japan Ministry of National Land & Transportation
Penetration Test	Assignment No.: 04CA21758	Underwriters Laboratories U.S.A.
Uplift Resistance	UL 2218	Underwriters Laboratories U.S.A.
Snow Resistance	The observation of outdoor exposed roof	Hokkaido Northern Regional Building Research Institute, Japan.

STANDARD PACKING DETAIL

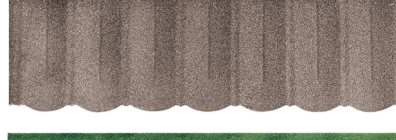
- SPANY Tile - 400 tiles per pallet with weight about 1,200kg
- PALLET DIMENSION - Wooden Pallet dimension of 1,380mm×1,080mm
- EXPORT STANDARD - 14 pallets (5,600 SPANY tiles) with sufficient SPANY accessories can be packed into a standard 20ft(6,10m) container.
- HANDLING & STORAGE - If stored outside, you should place a cover over the tiles to prevent damage and to keep them dry. Be careful when handling tiles to avoid damage to the surface. In the event of minor damages, use the finishing kit to repair it.
- Rust free nails should be used for all installations.

Color Guide

101	Charcoal Grey	
102	Teak	
103	Coffee Brown	
104	Terracotta	
105	Garnet	
106	Piebald	
107	Blade Green	
108	Sea Green	
109	Dark Green	
110B	Slate Grey	

※ The above color samples may look different from the original products. Please refer the actual sample or Roser's color chart for the actual product's color.
※ To meet each and every construction requirements, other types of accessories are also available.

Stone Coated Steel Roof

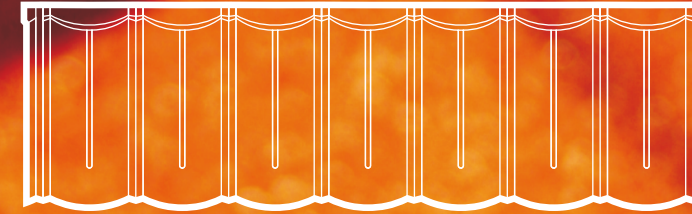

ROSER. The reliable partner for roofing solutions.

ROSER ROOFING SYSTEM

Stone Coated Steel Roof www.ROSER.com

Technical Information

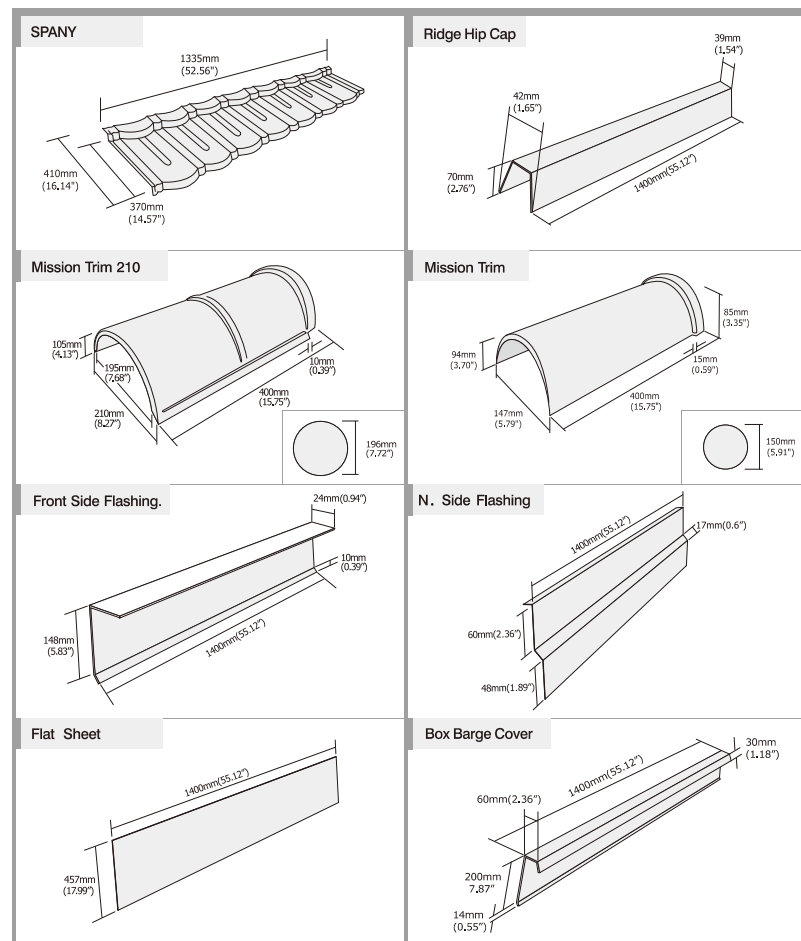

※ Other colors available, please check with Roser about other color information.

Stone Coated Steel Roof

A leading manufacturer of lightweight stone-coated steel roofing products.

SPANY®



ROSER CO.,LTD.
ROSER ROOFING SYSTEM
Stone Coated Steel Roof www.ROSER.com

VERSION:RSBCC-04

The above logos and names are registered trademarks of Roser Co.,Ltd. © 2007 Roser Co.,Ltd.



SEOUL MARKETING OFFICE
One Bldg.12F.,121, Teheran-ro, Gangnam-gu,
Seoul, KOREA. T +82 2 566 7663
Marketing@roser.com F +82 2 563 7663

HEAD OFFICE / FACTORY
43, Nae-Ri-19, Amnyang-myeon, Gyeongsan-si,
Gyeongsangbuk-do, KOREA. T +82 53 817 5000
Roser@roser.com F +82 53 817 5454



A Roofing system that re-defines the definition of a good roof



SPANY Tile

Overall Length	1325mm (52.16")
Length of Cover	1265mm (49.80")
Width of Cover	374mm (14.72")
Roof Cover/Tile Coverage	0.473m ² (5.07ft ²)
Weight	2.11 tile/m ² 3.0kg (6.61pd)

WHAT IS GALVALUME :

*Galvalume[®] steel is the result of an ideal alloy of Aluminum and Zinc. It consists of Aluminum (55% in weight ratio but 80% in surface volume ratio), Zinc (43.4% in weight), and Silicon (1.6% in weight ratio) so it has both Aluminum-unique corrosion-resistance and heat resistance and Zinc-unique "Galvanic Behavior".

Cross Section of a Roser stone coated steel roofing tile :

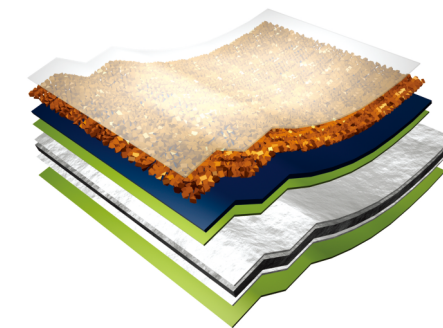

- Clear acrylic over-glaze protective coating.
- Roofing Granule coating
- Adhesive basecoat
- Protective surface coating
- Aluminum/ Zinc coating
- Commercial grade steel core
- Aluminum/ Zinc coating
- Protective surface coating

Columned diagram :

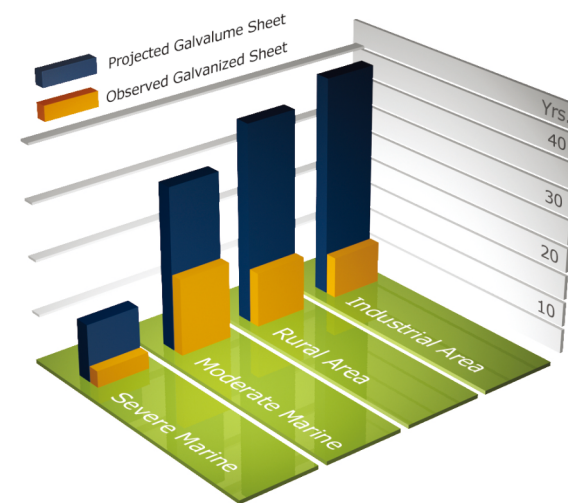

Atmospheric test program of *Galvalume[®] sheet early R&D samples; year to first rust

- Projected life is based on accurately measured panel weight losses caused by corrosion over time.
- The information contained in the Graph is From the May 1999 issue of the Rural Builder Magazine.

*Galvalume[®] is registered a trademark of BIEC International, inc.

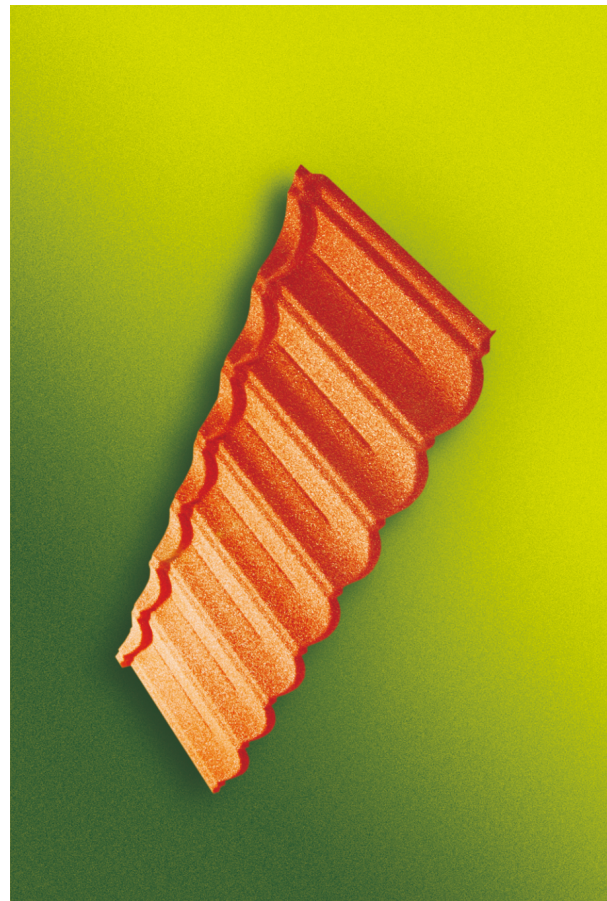

SPANY is an excellent roofing system by its shape and design. It can improve the look of your new house or existing roof instantly. It is available in a variety of ten different fashionable colors. With its overlapped and interlocked installation system, SPANY is designed and manufactured to protect your home from the most extreme weathers.

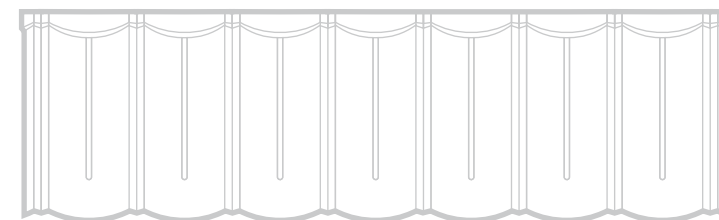

LIGHTWEIGHT

SPANY is wide, which means that every tile covers a large area. It's lightweight (only about 1/6 weight of traditional clay or cement tile), therefore, you can save considerable amounts of money on extra structural support, transportation, workmanship, and installation costs.

RE-ROOFING

SPANY can bring a new look to your home if you are unsatisfied with your existing roof. It is designed to be easily installed over any existing roof in a matter of a few days.

MANUFACTURED TO INTERNATIONAL STANDARDS

To meet the rapidly changing demands of the 21st century, ROSER CO., LTD. is ISO9001 certified, the quality management system standard accepted in more than 75 countries around the world.

EASY HANDLING

SPANY can be cut, bent, and shaped to meet the most demanding roof design from as low as a 12-degree pitch to a 90-degree angle pitch.

EXCELLENT COLOR CHOICE

SPANY has a great selection of colors to choose from which will suit each and every customer's preference. The colors blend in perfect harmony to give a natural and dazzling look to your roof.

OUTSTANDING DURABILITY:

SPANY is designed and manufactured to withstand all kinds of most severe weather such as extremely hot and cold weather, strong wind, and heavy rain. The core strength is *Galvalume[®] steel (Al-Zn Alloy). *Galvalume[®] steel has great long-term corrosion resistance. On both sides of this core strength additional coating systems applied respectively for enhanced durability. The stone chips are then embedded to provide enhanced strength and beauty.

